

Standard D-1 and D-2 style refueling nozzles differ only in the inlet coupling. Some military applications favor the D-1 over the D-2 and vice versa. Now a D-3 Universal Inlet Coupling, qualified in accordance with SAE AS5877, is available which makes it possible to vary the inlet from the straight (D-2) to the 45° (D-1) inlet configuration. This can be done without tools simply by swiveling the inlet to the configuration desired (0-45° and all angles in between).

Eaton's Carter product line part number 47566 D-3 Universal Inlet Coupling can be purchased separately, or as option "N" on Carter Model 64201 or Model 64349 refueling nozzles. See brochures for Model 64201 and Model 64349 for additional details.

The D-3 Universal Inlet Coupling will retrofit onto any existing Model 64201 nozzle and most Model 64349 nozzles (**see CAUTION note on this**

**page**). The existing straight or 45° inlet coupling is removed and the D-3 inlet coupling inserted in its place.

The new universal inlet, when installed onto a nozzle, will result in a slightly increased length than the standard D-1 and D-2 nozzles. See envelope dimensions (back) for details.

#### Features

- May be used for both D-1 and D-2 applications
- Existing Model 64349 and Model 64201 nozzles can be retrofitted. (**See CAUTION note when considering retrofitting older Model 64349 units.**)
- No tools required to change from D-1 to D-2 configurations
- Conversion from D-1 to D-2 or vice versa can be accomplished without disconnecting the nozzle from the hose

- No flow penalty
- Continuity between the moving parts in the new swivel is maintained
- Latest swivel design from Model 64201 nozzle used – replaceable wear ring used for longer swivel life

#### CAUTION

*Older Model 64349 nozzles (D-1 or D-2) may be badly worn at the body swivel joint and it may not be possible to get a leak tight fit with the new D-3 universal coupling. Model 64349 nozzles with serial numbers 8200 and higher include a replaceable wire ball race ring and can safely be retrofitted with the D-3 inlet (after inspection of the wear ring to determine if replacement is needed). Eaton does not recommend retrofitting any Model 64349 nozzle that does not have a replaceable wire ball race ring in its inlet.*



**D-3 Inlet Coupling**

Shown in D-2 straight inlet configuration



**Model 64201N**

Shown in D-1 45° configuration



**Model 64349N**

Shown in D-2 straight inlet configuration



Powering Business Worldwide

## Envelope Dimensions

Dimensions shown in inches (millimeters)

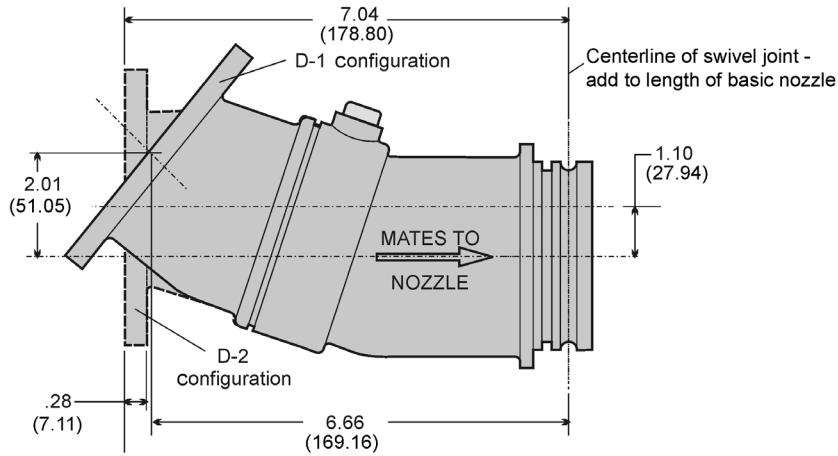

## Ordering Information

To add a D-3 Universal Inlet Coupling to an existing nozzle configuration, or when replacing a D-1 or D-2 inlet with the new D-3 inlet, order part number 47566 (NSN 4730-01-534-0950). The existing balls, ball retaining screw and seal may be reused if no damage is evident.

When specifying the D-3 inlet as part of a new nozzle order, indicate Option "N" after the basic nozzle model (e.g. 64349N or 64201N). Option "N" replaces either Option "H" or Option "J".